

ENGINEERED
I-JOISTS

hyJOIST

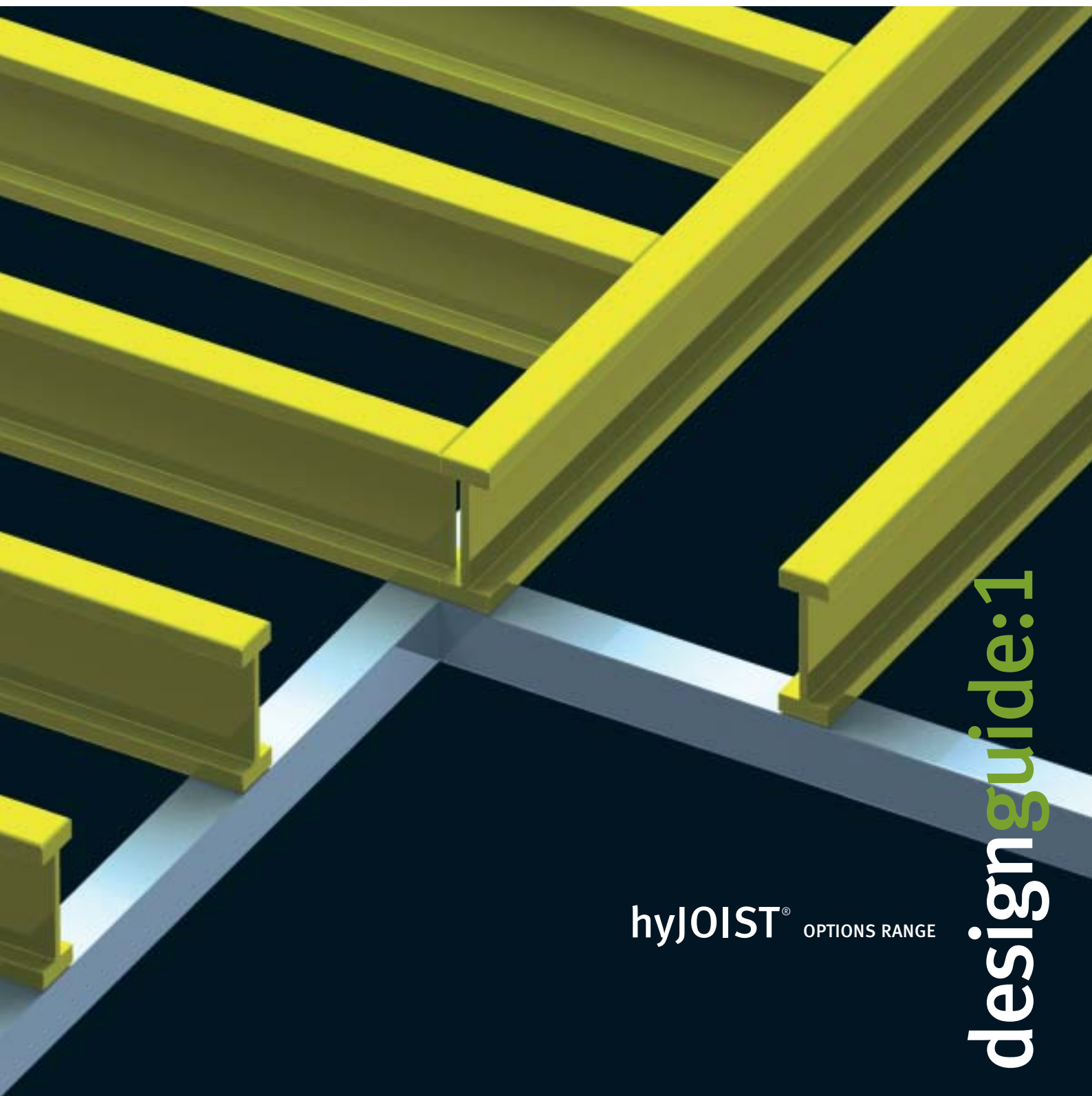

hyJOIST[®] OPTIONS RANGE

designguide:1

More options for more economical floor joist layouts

Select the **economy section** (HJ240 45, HJ300 45 & HJ360 63) of appropriate depth to accommodate the spans of the main area of the floor. Cater for any larger spans in the floor area using the wider flange options of corresponding depth.

‘Same old’ quality and performance associated with Hybeam

- **Product quality** – Plywood Association of Australasia ‘Product Certified’ for peace of mind
- **Technical support** – experienced engineering support, simply call **1800 808 131**
– ‘on-the-ground’ specialist technical representatives, willing and able to help
- **Responsible conservative design** – ‘maintaining the standard for consistency of performance’
- **‘Off the shelf’ convenience** – readily available, ex stock via a comprehensive distribution network, simply cut to length and install
- **H2s termite protected** – ‘protected to the core’ (optional) termite protection applicable for areas of Australia south of the Tropic of Capricorn

Design

Consider the **‘hyJOIST SELECTION GUIDE’** below, summarising key parameters involved in selection of the appropriate joist sections. Information contained in this publication applies for floor joists used in houses. For more information refer either to this publication or **designIT** software as set out in the following table. Use of **designIT** will provide a wider range of options and allow more optimum design.















Design information	Literature	designIT
Spanning capabilities	✓	✓
Bearing requirements	✓	✓
Blocking for lateral support	✓	✓
Transfer of wind / earthquake forces through the floor depth	✓	
Web holes – permitted locations related to size, shape and span	✓	✓
Details for limited notching of flanges (at end supports only)	✓	
Hangers, brackets and fixing requirements for support of joists	✓	✓
Framing for stair voids		✓
Cantilevers for balconies	✓	✓
Joists supporting parallel load bearing walls	✓	✓
Joists supporting perpendicular load bearing walls (including cantilevers)		✓
Continuous hyJOIST blocking for support of load bearing walls	✓	✓

Installation

Details for installation (referenced in this Design Guide) are contained in a separate publication ‘Guide for Installation’.



hyJOIST selection guide

DIMENSIONS FOR DETAILING				SPAN - FLOOR JOISTS FOR HOUSES									
OVERALL DEPTH (mm)	CLEAR DISTANCE BETWEEN FLANGES	FLANGE WIDTH (mm)		FLANGE OUTSTAND (mm) ¹	HYJOIST SECTION CODE	WEIGHT OF 5 METRE LENGTH	MAXIMUM HOLE SIZE FOR SERVICES ²	SINGLE SPAN		CONTINUOUS SPAN		BALCONY CANTILEVER ³	
		45	63					90	JOIST SPACING (mm)	450	600	450	600
		18	27	39				RECOMMENDED SPAN RANGE - m					
200	125				HJ200 45	14.5 kg		3.5 to 3.8	3.1 to 3.6	4.0 to 4.5	3.7 to 4.2	1.0	0.9
240	165				HJ240 45	15.3 kg		3.8 to 4.5	3.5 to 4.2	4.5 to 5.1	4.2 to 4.7	1.2	1.0
					HJ240 63	19.4 kg		4.4 to 4.9	4.0 to 4.5	5.0 to 5.5	4.5 to 5.1	1.3	1.2
					HJ240 90	27.3 kg		4.9 to 5.4	4.5 to 5.0	5.6 to 6.1	5.1 to 5.6	1.5	1.4
300	225				HJ300 45	16.9 kg		4.6 to 5.1	4.3 to 4.7	5.1 to 5.8	4.6 to 5.4	1.4	1.3
					HJ300 63	21.0 kg		5.0 to 5.5	4.6 to 5.1	5.6 to 6.3	5.2 to 5.8	1.5	1.4
					HJ300 90	29.4 kg		5.6 to 6.1	5.2 to 5.7	6.4 to 7.0	5.9 to 6.4	1.7	1.6
360	285				HJ360 63	22.6 kg		5.6 to 6.2	5.2 to 5.7	6.3 to 6.8	5.6 to 6.0	1.7	1.6
					HJ360 90	31.5 kg		6.3 to 6.8	5.8 to 6.3	7.2 to 7.8	6.7 to 7.1	1.9	1.8
400	325				HJ400 90	32.9 kg		6.8 to 7.2	6.3 to 6.7	7.6 to 7.9	6.7 to 7.1	2.0	1.9

1. Used to determine the thickness of packing to pack web flush with flanges

2. Refer to page 9 / designIT for permitted hole locations and limitations

3. Refer to page 10 / designIT for further design information

Bearing support

For joists not transferring load from upper walls

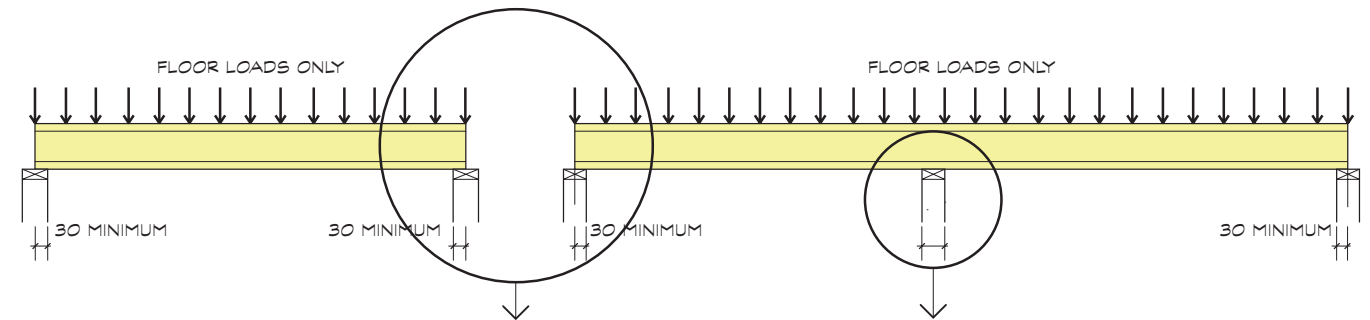

	END SUPPORTS SINGLE OR CONTINUOUS SPANS	INTERMEDIATE SUPPORTS CONTINUOUS SPAN	
JOIST SPACING (mm)	ALL	450	600
MINIMUM BEARING (mm)	30	45	65

designIT may give reduced bearing requirements for specific cases.

For joists transferring upper storey wall and roof loads at supports

End supports - single or continuous spans

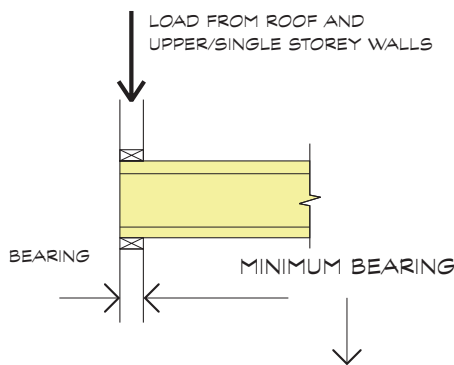

For joists supporting load bearing walls at end supports, provide bearing as specified in the table below or alternatively install continuous hyJOIST blocking/‘rimboard’/boundary joist.

LOAD TYPE	JOIST SPACING (mm)	
	450	600
	MINIMUM BEARING (mm)	
SHEET ROOF	45	65 ¹
TILE ROOF	65	90 ²

1. If web stiffeners installed bearing may be reduced to 45 mm
2. If web stiffeners installed bearing may be reduced to 65 mm
3. For all cases bearing may be reduced to 30 mm if continuous full depth blocking or compression blocks are installed
4. Web stiffener installation as per Detail F6 in the ‘Guide for Installation’
5. designIT may give a reduced bearing requirement

Intermediate supports - continuous spans

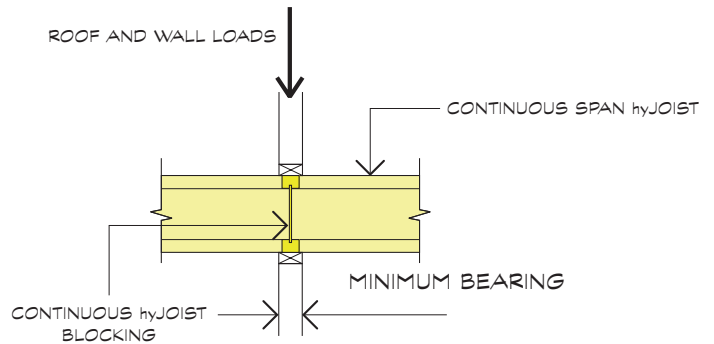

Minimum bearing to be as for joists supporting floor loads only. Load bearing wall to be supported by continuous full depth hyJOIST blocking.

Concentrated loads from jamb studs/posts

Use compression blocks to transfer loads through to supports as shown. Refer to Detail F18 in the ‘Guide for Installation’.

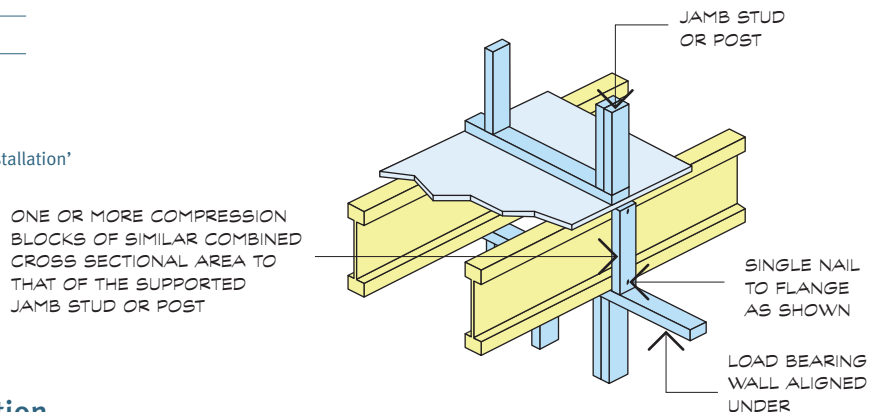

For lower storey of 2 storey construction

Continuous full depth hyJOIST blocking should be installed to transfer compression loads from load bearing walls to the supports. In most cases continuous hyJOIST blocking will be adequate to support the roof, wall and floor loads. Refer to designIT for confirmation.

Support

Joist hangers

hyJOIST SECTION CODE	MANUFACTURER OR DISTRIBUTOR	FACE MOUNT HANGERS				TOP MOUNT HANGERS
		FULL DEPTH		PARTIAL DEPTH ³		HANGER CODE
		HANGER CODE	MINIMUM N ^o OF NAILS TO BEARER	HANGER CODE	MINIMUM N ^o OF NAILS TO BEARER	
HJ200 45	Pryda	LF190/50	6	FB50180	8	LT200/50
	Mitek	IBHF20050	6			IBHT20050
HJ240 45	Pryda	LF235/50	6	FB50220	8	LT240/50
	Mitek	IBHF24050	6			IBHT24050
HJ240 63	Pryda	LF235/65	8	FB65170	10	LT240/65
	Mitek	IBHF24065	8			IBHT24065
HJ240 90	Pryda	LF235/90	8	FB90200	10	LT240/90
	Mitek	IBHF24090	8			IBHT24090
HJ300 45	Pryda	LF297/50	8	FB50220	10	LT300/47
	Mitek	IBHF30050	8			IBHT30050
HJ300 63	Pryda	LF290/65	8	FB65170	10	LT302/65
	Mitek	IBHF30065	8			IBHT30065
HJ300 90	Pryda	LF290/90	8	FB90200	12	LT300/90
	Mitek	IBHF30090	8			IBHT30090
HJ360 63	Pryda	LF340/65	8	FB65170	12	LT360/65
	Mitek	IBHF36065	8			IBHT36065
HJ360 90	Pryda	LF350/90	10	FB90200	12	LT356/90
	Mitek	IBHF36090	10			IBHT36090
HJ400 90	Pryda			LF350/90	14	LT400/90
	Mitek	IBHF40090	10			IBHT40090

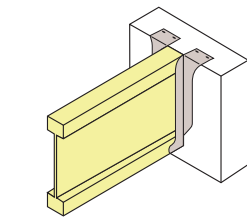

TOP MOUNT HANGER

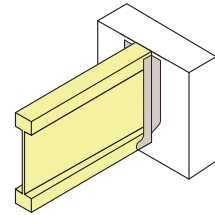

FULL DEPTH FACE MOUNT HANGER

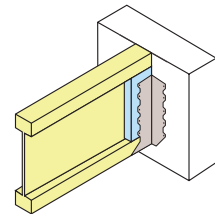

PARTIAL DEPTH FACE MOUNT HANGERS WITH PACKING TO WEB

1. Nailing specified is for brackets face fixed to hySPAN or JD4 (or better) timber bearer or wale plate.
2. Brackets to be installed strictly in accordance with bracket manufacturers' recommendations. Note, nails for FB hangers are 35 x 3.15 flat head type; for all other hangers 40 x 3.75 flat head nails are specified.
3. Partial depth face mount hangers to be installed with web packing - install as for web stiffeners refer Detail F6.

Skew angle bracket for oblique joists

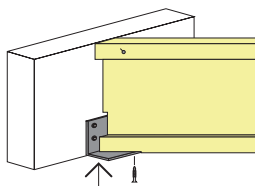

SKREW ANGLE BRACKET AVAILABLE FROM PRYDA - PRYDA CODE: LV51A

Webs may be cut to accommodate the top flange of steel beams in accordance with Detail F8 in the 'Guide for Installation'. Web notches may be combined with flange notching.

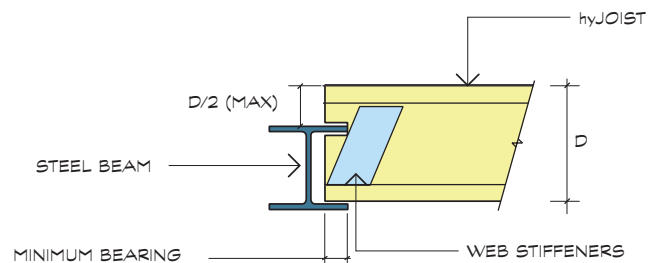

Limited notching at end supports is allowed

Flange Notches – Bottom and/or top flanges may be notched to maximum depth 12 mm – refer Detail F7 in the 'Guide for Installation'.

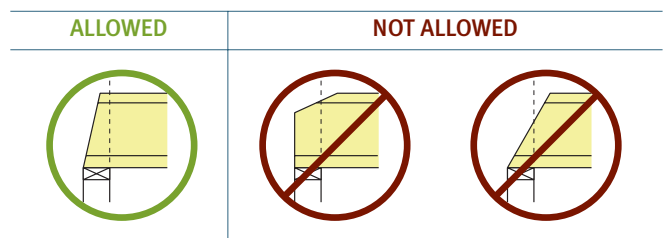
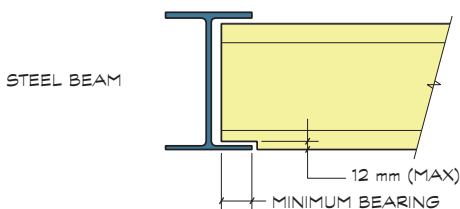

Typical floor layout

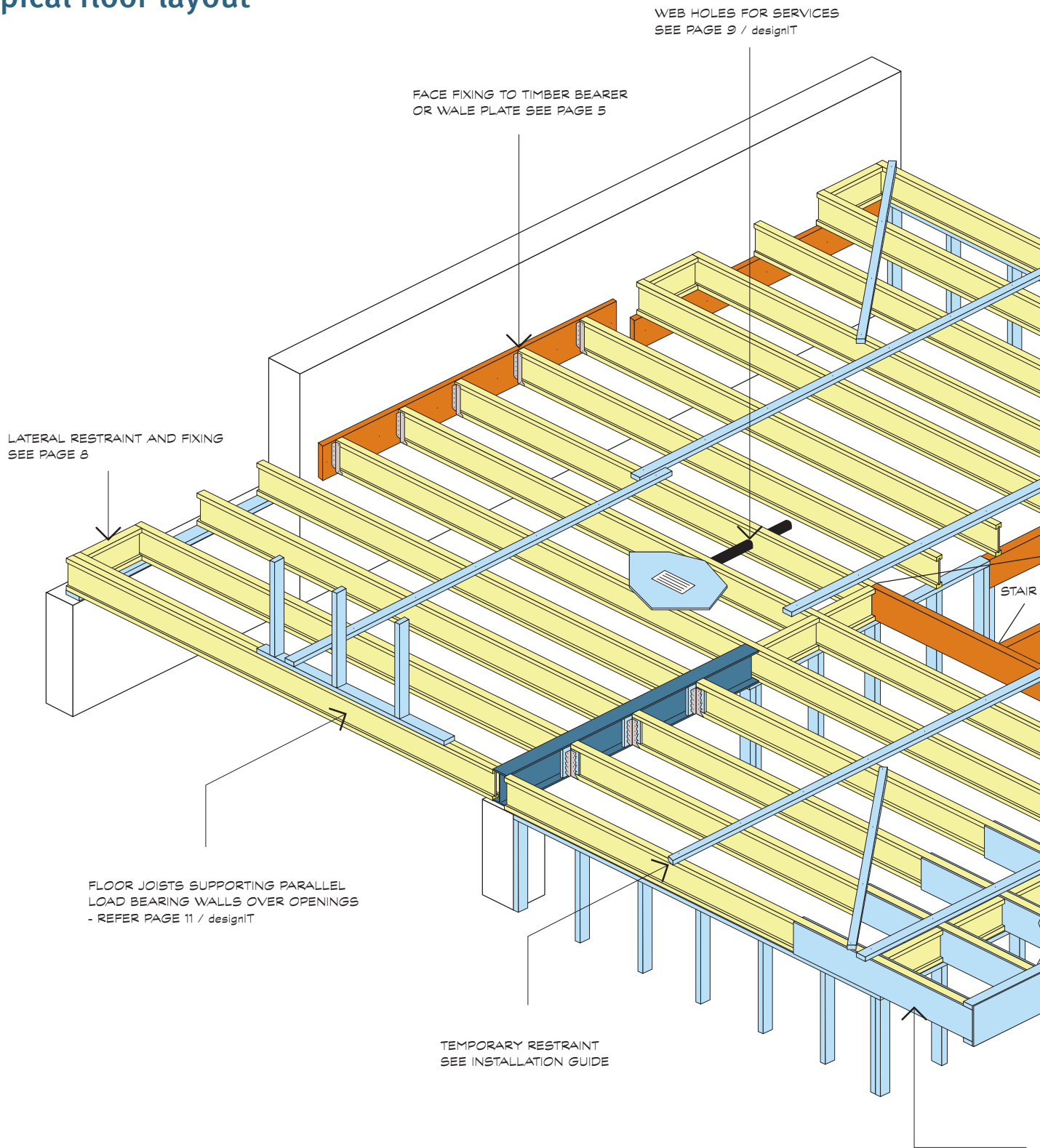

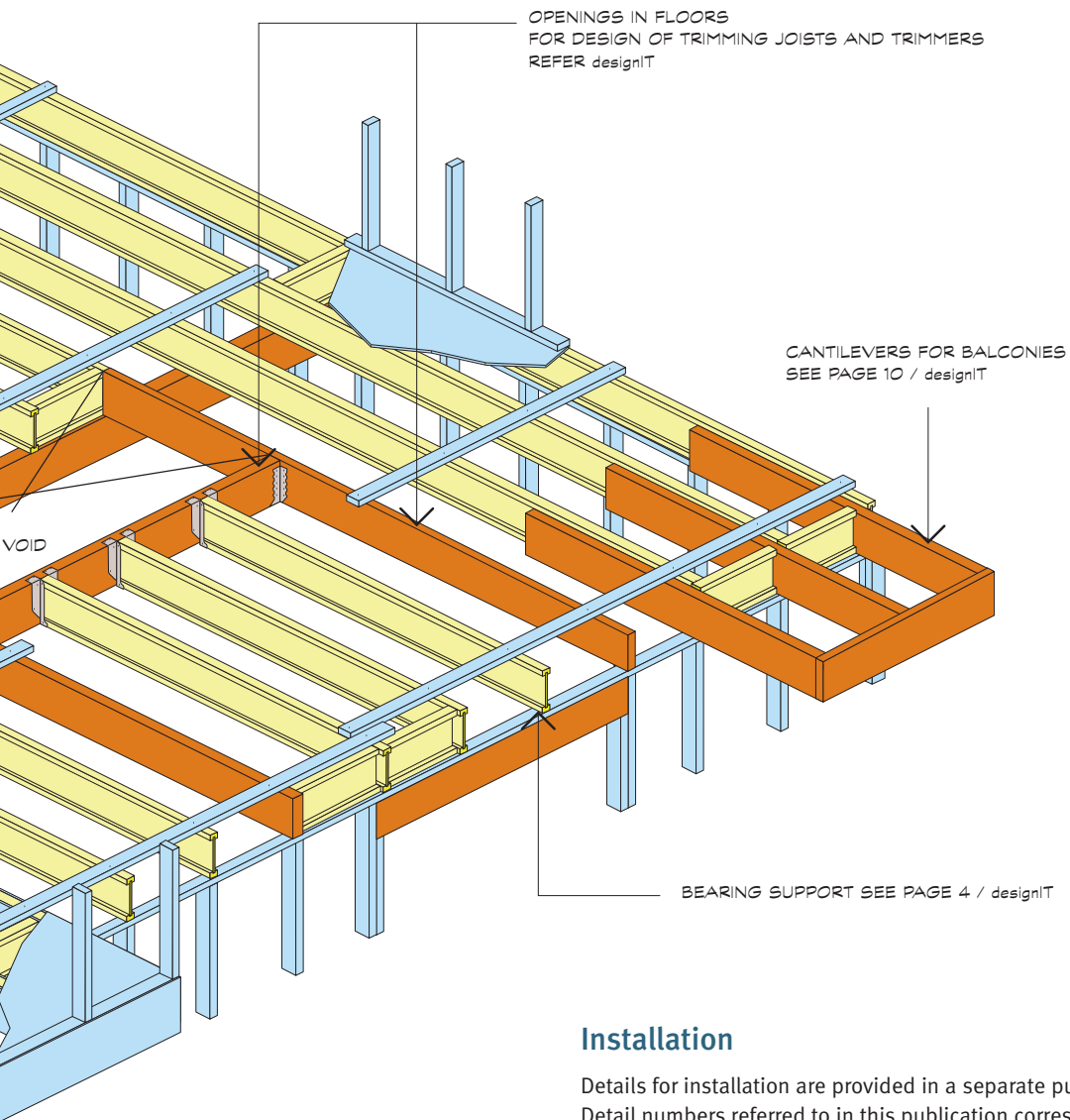

Installation

Details for installation are provided in a separate publication 'Guide for Installation'. Detail numbers referred to in this publication correspond to those given in the installation guide.

Storage

Prior to installation hyJOIST should be stacked on level bearers, at least 150 mm clear of the ground and kept dry.



CANTILEVERS TO SUPPORT LOAD
BEARING WALLS - REFER designT

Lateral restraint requirements

Joists need to be installed and held plumb and straight if they are to perform to expectations.

At supports

1. Joists are to be fixed accurately in position at supports using nails or screws as per Detail F5 in the 'Guide for Installation'.
2. Specify hyJOIST blocking or equivalent to be installed in accordance with requirements given in the 'Guide for Installation'.
The installation requirements for blocking, bracing, 'rimboard' or boundary joists are specified in Details F1, F2, F3 and F17.

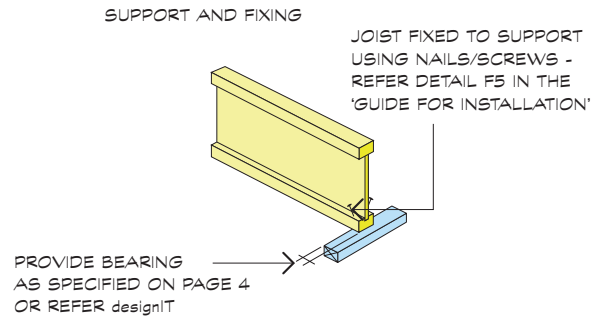

Requirements for intermediate support

Provided care is taken to ensure that joists are installed plumb and straight between supports there is no requirement for installation of intermediate blocking. During construction, prior to walking on bare joists, the top flange of hyJOIST should be restrained at not more than 2.5 m intervals using battens or equivalent fixed back to points of rigidity as shown in the 'Guide for Installation'.

Transfer of wind and earthquake forces between floors

The design of houses includes quantification of lateral loads due to wind and earthquake. Racking forces determined for design of upper level bracing must be able to be transferred through the floor depth to the lower level. Racking forces in the direction of the joists are catered for by the considerable longitudinal shear capacity of the joists. For forces perpendicular to the joists, blocking and/or perimeter 'rimboard' and their associated fixings (installed to provide lateral restraint) may or may not be adequate. In particular, the fixing of the floor diaphragm to 'rimboard'/blocking and in turn, fixing of 'rimboard'/blocking to the supports must be adequate to resist the horizontal racking force used for design of the upper floor wall bracing system.

Blocking using hyJOIST with the required fixing is a practical and easy to install solution.

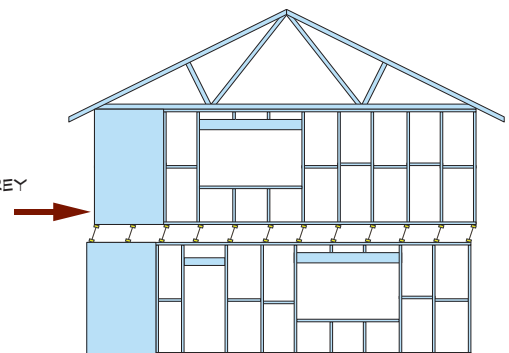

RACKING LOADS NEED TO BE TRANSFERRED THROUGH FLOORS TO THE LOWER STOREY WALL BRACING SYSTEM

Using plywood closures – at external walls

NAIL SPACING AS REQUIRED FOR THE UPPER STOREY WALL BRACING

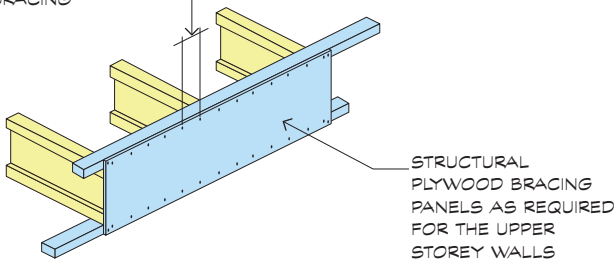

Using hyJOIST blocking – external and internal walls

At external walls, 'rimboard' may be used in conjunction with hyJOIST blocking.

NAIL FIX PLATE TO BLOCKING AND BLOCKING TO SUPPORT TO MATCH CAPACITY OF NAILING REQUIRED FOR THE UPPER STOREY BRACING

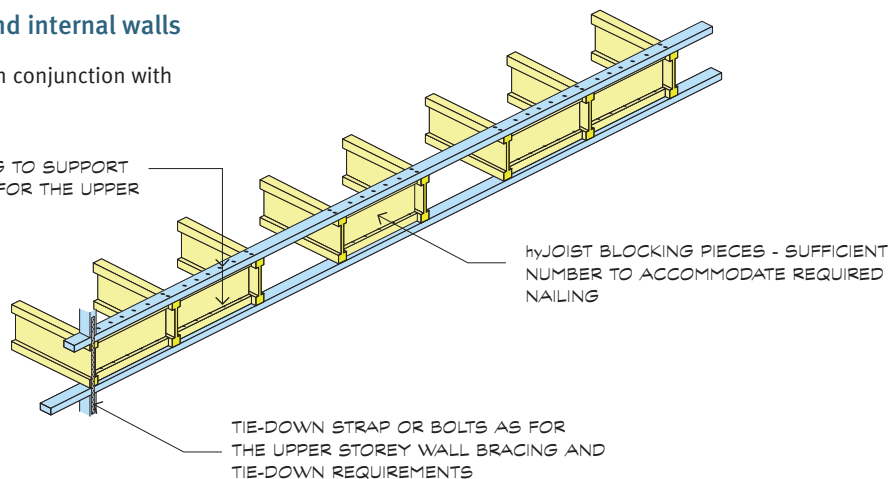

Web holes for hyJOIST

Holes may be cut through the web of hyJOIST provided they are located within the central part of the span as specified below.

For hole sizes other than those included below refer to the web hole calculator in designIT. For cases involving non-uniform loading or where the possibility of locating the hole closer to supports needs to be assessed, use the web hole option in the floor joist calculator in designIT.

CIRCULAR HOLES

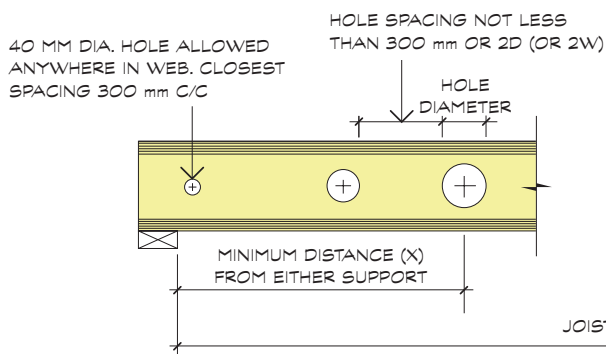

RECTANGULAR HOLES

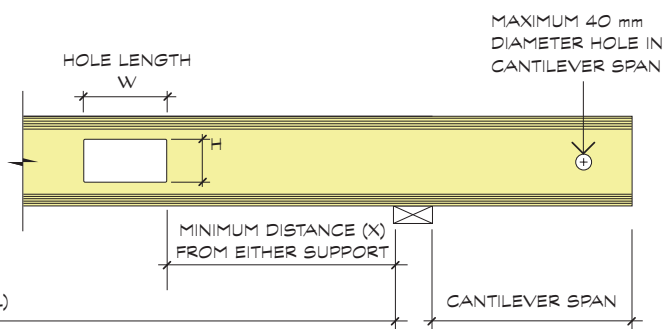

hyJOIST SECTION CODE	MAXIMUM HOLE DIAMETER (mm)	MINIMUM DISTANCE FROM SUPPORT 'X'	HOLE DIAMETER (mm)				
			ø80	ø110	ø125	ø150	
HJ200 45	ø125	0.34L	0.16L	0.28L	0.34L	N/A	
HJ240 45	ø165	0.38L	0.12L	0.21L	0.26L	0.33L	
HJ240 63							
HJ240 90	ø225	0.41L	0.10L*	0.15L	0.18L	0.24L	
HJ300 45							
HJ300 63							
HJ300 90	ø285	0.42L	0.3 m*	0.10L*	0.14L	0.20L	
HJ360 63							
HJ360 90							
HJ400 90	ø325	0.40L	0.3 m*	0.3 m*	0.3 m*	0.3 m*	0.05L*
							0.08L*

* Minimum distance from any support is 0.3 metres

hyJOIST SECTION CODE	HOLE SIZE		PERMITTED LOCATIONS FOR RECTANGULAR HOLES								
	HEIGHT (mm)	LENGTH (mm)	L	Actual Span 'L' in metres							
			X	Minimum distance from the side of the hole to any support – (m)							
HJ200 45	125	250	L	≤ 3.8	4.0	4.2	4.4	4.5			
			X	0.34L	1.38	1.59	1.80	1.90			
HJ240 45	165	330	L	≤ 3.5	3.6	3.8	4.0	4.2	4.4	4.6	4.7
			X	0.38L	1.36	1.50	1.65	1.80	1.95	2.10	2.18
HJ240 63	165	330	L	≤ 3.5	5.5						
			X	0.38L	2.13						
HJ240 90	165	330	L	≤ 5.8	6.0	6.1					
			X	0.38L	2.36	2.45					
HJ300 45	225	400	L	≤ 3.6	3.8	4.0	4.2	4.4	4.6	> 4.6	
			X	0.41L	1.58	1.71	1.84	1.97	2.10	†	
HJ300 63	225	400	L	≤ 5.2	5.4	5.6	5.8	6.0	6.2	6.3	
			X	0.41L	2.25	2.39	2.54	2.69	2.83	2.91	
HJ300 90	225	400	L	≤ 6.4	6.6	6.8	7.0				
			X	0.40L	2.73	2.88	3.04				
HJ360 63	285	500	L	≤ 5.4	5.6	5.8	6.0	6.2	6.4	6.6	6.8
			X	0.42L	2.37	2.49	2.62	2.75	2.88	3.02	3.15
HJ360 90	285	500	L	≤ 7.2	7.4	7.6	7.7				
			X	0.40L	2.97	3.10	3.17				
HJ400 90	325	600	L	≤ 8.0							
			X	0.40L							

† Use the web hole option in the floor joist calculator in designIT. Interpolate to obtain values of 'X' for spans intermediate between the values given.

Notes:

- Data applies for floor joists supporting uniform loads (and concentrated live load not exceeding 1.8 kN).
- Hole locations closer to supports may be possible for some load and support conditions; refer to the 'floor joist calculator' in designIT software or contact Timberbuilt.
- Spacing between holes to be not less than 300 mm or twice the width (or twice the diameter) of the larger hole.
- Not more than three holes with width or diameter greater than 80 mm in any span.
- For cantilever spans holes greater than 40 mm diameter are not permitted.

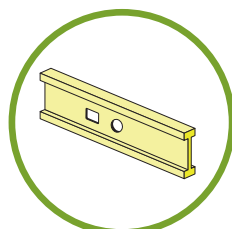

DO CUT IN WEB AREA AS SPECIFIED

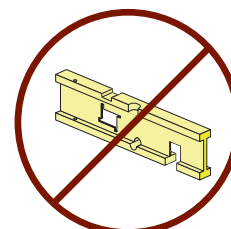

DO NOT CUT, NOTCH OR BORE THROUGH FLANGE

Cantilevers for balconies

Balcony cantilevers, subject to external weather exposure can be provided using preservative treated and protected outriggers as per Details F11 and F12 in the 'Guide for installation'. For weather proofed applications hyJOIST can be cantilevered to provide balcony support as per Detail F13 also in the 'Guide for installation'.

Outriggers can be seasoned stress-graded timber or hySPAN, either nested against the hyJOIST web and bearing on the top of the bottom flange or placed adjacent to the hyJOIST bearing directly on the support. Diagrams illustrating these configurations are shown below.

Some options for outriggers are included in the following table. These have all been determined for 2 kPa balcony floor load. For other floor loads and to consider other options refer to designIT.

hyJOIST SECTION CODE	JOIST SPACING (mm)	MAXIMUM BALCONY CANTILEVER (m)	OUTRIGGER OPTIONS	
			NESTED OUTRIGGER	ADJACENT OUTRIGGER
HJ200 45	450	1.0	2/120 x 35 MGP12	150 x 36 hySPAN 190 x 45 F7
	600	0.9	2/120 x 35 MGP12	130 x 45 hySPAN
HJ240 45	450	1.2	2/150 x 36 hySPAN 2/140 x 45 F8/MGP10	170 x 45 hySPAN 190 x 45 F8/MGP10
	600	1.0	150 x 45 hySPAN 2/140 x 35 F7	150 x 45 hySPAN 190 x 45 F7
HJ240 63	450	1.3	2/150 x 36 hySPAN	170 x 45 hySPAN 190 x 45 F8/MGP10
	600	1.2	2/150 x 36 hySPAN	200 x 45 hySPAN 240 x 45 F7
HJ240 90	450	1.5	2/160 x 45 hySPAN*	Not Recommended
		1.4	2/150 x 36 hySPAN	
	600	1.4	2/160 x 45 hySPAN*	
HJ300 45	450	1.4	200 x 36 hySPAN 190 x 45 MGP12	200 x 36 hySPAN 240 x 45 F7
	600	1.3	200 x 45 hySPAN	200 x 45 hySPAN 240 x 45 F7
HJ300 63	450	1.5	200 x 45 hySPAN	200 x 45 hySPAN 240 x 45 F7
	600	1.4	200 x 45 hySPAN	200 x 45 hySPAN 240 x 45 F7
HJ300 90	450	1.7	2/200 x 36 hySPAN	Not Recommended
	600	1.6	2/200 x 36 hySPAN	
HJ360 63	450	1.7	240 x 45 hySPAN	240 x 45 hySPAN 290 x 45 F7
	600	1.6	240 x 45 hySPAN	240 x 45 hySPAN 290 x 45 F7
HJ360 90	450	1.9	240 x 63 hySPAN	Not Recommended
	600	1.8	2/240 x 45 hySPAN	
HJ400 90	450	2.0	300 x 45 hySPAN	Not Recommended
	600	1.9	300 x 45 hySPAN	

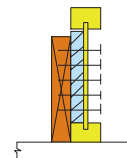

ADJACENT OUTRIGGER

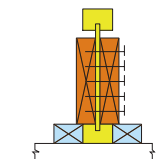
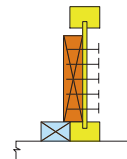

SINGLE SECTION

DOUBLE SECTION

NESTED OUTRIGGER

* Not a standard hySPAN section: may be cut from a larger hySPAN section to nest between flanges with appropriate clearance

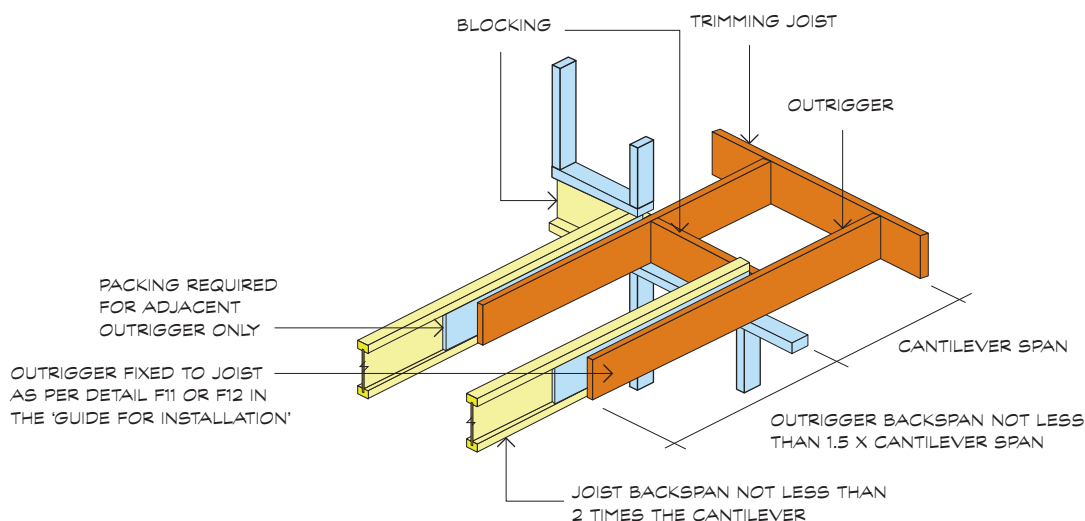

Joists supporting parallel load bearing walls

SHEET ROOF & CEILING												
hyJOIST SECTION CODE	ROOF LOAD WIDTH (m)						ROOF LOAD WIDTH (m)					
	1.8	2.4	3.6	4.8	6.0	7.2	1.8	2.4	3.6	4.8	6.0	7.2
	MAXIMUM SINGLE SPAN (m)						MAXIMUM CONTINUOUS SPAN (m)					
HJ200 45	2.7	2.5	2.2	2.0	1.7	1.5	2.9	2.5	2.0	1.6	1.3	1.2
2/HJ200 45	3.5	3.3	3.0	2.8	2.6	2.4	4.1	3.9	3.4	3.1	2.7	2.3
HJ240 45	3.1	2.9	2.6	2.4	2.2	1.9	3.9	3.3	2.6	2.1	1.8	1.5
2/HJ240 45	4.1	3.9	3.5	3.2	3.0	2.8	4.7	4.3	3.8	3.4	3.2	2.9
HJ240 63	3.5	3.2	2.9	2.6	2.2	1.9	3.8	3.3	2.5	2.1	1.8	1.5
2/HJ240 63	4.5	4.3	3.9	3.6	3.3	3.1	5.4	5.2	4.5	4.1	3.5	3.0
HJ240 90	4.0	3.8	3.4	3.1	2.9 ₄₅	2.5 ₄₅	4.9 ₇₀	4.3 ₈₀	3.4 ₈₀	2.8 ₈₀	2.3 ₈₀	2.0 ₈₀
HJ300 45	3.8	3.5	3.2	2.9	2.7 ₄₅	2.5 ₄₅	4.7 ₇₀	4.4 ₉₀	3.4 ₉₀	2.8 ₉₀	2.4 ₉₀	2.0 ₉₀
2/HJ300 45	4.8	4.6	4.2	3.9	3.6	3.4	4.9	4.6	4.2	3.9	3.6	3.3
HJ300 63	4.2	3.9	3.5	3.2 ₄₅	2.9 ₄₅	2.5 ₄₅	5.0 ₈₀	4.4 ₉₀	3.4 ₉₀	2.8 ₉₀	2.3 ₉₀	2.0 ₉₀
2/HJ300 63	5.1	4.9	4.6	4.3	4.0	3.8	6.1	5.8	5.1	4.6	4.2 ₇₀	3.9 ₈₀
HJ300 90	4.7	4.5	4.1 ₄₅	3.8 ₆₅	3.4 ₆₅	2.9 ₆₅	5.6	5.0 _#	3.9 _#	3.2 _#	2.7 _#	2.4 _#
HJ360 63	4.7	4.5 ₄₅	4.1 ₄₅	3.7 ₆₅	3.4 ₆₅	3.0 ₆₅	5.5 _#	5.1 _#	3.9 _#	3.2 _#	2.7 _#	2.4 _#
2/HJ360 63	5.7	5.5	5.1	4.8	4.6	4.4 ₄₅	6.1	6.0	5.5	5.2 ₉₀	4.8 _#	4.4 _#
HJ360 90	5.2	5.0 ₄₅	4.7 ₆₅	4.0 ₆₅	3.4 ₆₅	2.9 ₆₅	5.9 _#	5.0 _#	3.9 _#	3.2 _#	2.7 _#	2.4 _#
HJ400 90	5.6 ₄₅	5.3 ₄₅	4.9 ₆₅	4.0 ₆₅	3.4 ₆₅	2.9 ₆₅	5.8 _#	5.0 _#	3.9 _#	3.2 _#	2.7 _#	2.4 _#

TILE ROOF & CEILING												
hyJOIST SECTION CODE	ROOF LOAD WIDTH (m)						ROOF LOAD WIDTH (m)					
	1.8	2.4	3.6	4.8	6.0	7.2	1.8	2.4	3.6	4.8	6.0	7.2
	MAXIMUM SINGLE SPAN (m)						MAXIMUM CONTINUOUS SPAN (m)					
HJ200 45	2.2	1.8	1.3	NS	NS	NS	1.8	1.5	NS	NS	NS	NS
2/HJ200 45	2.9	2.7	2.3	2.1	1.7	NS	3.3	2.9	2.1	1.7	1.4	1.2
HJ240 45	2.5	2.3	1.7	1.4	NS	NS	2.4	1.9	1.4	NS	NS	NS
2/HJ240 45	3.4	3.1	2.7	2.4	2.2	1.9	3.6	3.2	2.8	2.2	1.8	1.5
HJ240 63	2.8	2.4	1.7	1.4	NS	NS	2.3	1.9	1.4	NS	NS	NS
2/HJ240 63	3.7	3.4	3.0	2.7	2.2	1.9	4.4	3.8	2.7	2.2	1.8	1.5
HJ240 90	3.3	3.0 ₄₅	2.3 ₄₅	1.8 ₄₅	1.5 ₄₅	1.3 ₄₅	3.1 ₈₀	2.5 ₈₀	1.8 ₈₀	1.4 ₈₀	1.2 ₈₀	NS
HJ300 45	3.1	2.8 ₄₅	2.3 ₄₅	1.8 ₄₅	1.5 ₄₅	1.3 ₄₅	3.1 ₉₀	2.5 ₉₀	1.9 ₉₀	1.5 ₉₀	1.2 ₉₀	NS
2/HJ300 45	4.1	3.7	3.3	3.0	2.7 ₄₅	2.5 ₄₅	4.1 ₃₀	3.7 ₄₅	3.2	2.8 ₈₀	2.4 ₉₀	2.0 ₉₀
HJ300 63	3.4 ₄₅	3.1 ₄₅	2.3 ₄₅	1.8 ₄₅	1.5 ₄₅	1.3 ₄₅	3.1 ₉₀	2.5 ₉₀	1.8 ₉₀	1.4 ₉₀	1.2 ₉₀	NS
2/HJ300 63	4.5	4.1	3.6	3.2 ₄₅	3.0 ₄₅	2.5 ₄₅	4.9 ₆₅	4.5 ₇₀	3.7 ₉₀	2.9 ₉₀	2.4 ₉₀	2.0 ₉₀
HJ300 90	4.0 ₄₅	3.6 ₆₅	2.7 ₆₅	2.1 ₆₅	1.7 ₆₅	1.5 ₆₅	3.6 _#	2.9 _#	2.1 _#	1.7 _#	1.4 _#	1.2 _#
HJ360 63	3.9 ₆₅	3.6 ₆₅	2.7 ₆₅	2.1 ₆₅	1.7 ₆₅	1.5 ₆₅	3.6 _#	3.0 _#	2.2 _#	1.7 _#	1.4 _#	1.2 _#
2/HJ360 63	5.0	4.7	4.2 ₄₅	3.8 ₆₅	3.5 ₆₅	2.9 ₆₅	5.4 ₇₀	4.9 ₉₀	4.2 _#	3.4 _#	2.8 _#	2.4 _#
HJ360 90	4.5 ₆₅	3.7 ₆₅	2.7 ₆₅	2.1 ₆₅	1.7 ₆₅	1.5 ₆₅	3.6 _#	2.9 _#	2.1 _#	1.7 _#	1.4 _#	1.2 _#
HJ400 90	4.5 ₆₅	3.7 ₆₅	2.7 ₆₅	2.1 ₆₅	1.7 ₆₅	1.5 ₆₅	3.6 _#	2.9 _#	2.1 _#	1.7 _#	1.4 _#	1.2 _#

Notes:

1. NS signifies the calculated span is less than 1.2 m.
2. Bearing for single span joists or the end supports of continuous joists, provide at least 30 mm bearing unless signified otherwise by a subscript value adjacent to the quoted maximum span. For the intermediate supports of continuous span joists, provide at least 65 mm bearing unless signified otherwise by a subscript value adjacent to the quoted span - ##, signifies that web stiffeners are required together with a bearing of 90 mm.



For more efficient floor design use

Free designIT software

Simple to use yet deceptively powerful, designIT® brings efficient and appropriate engineering design solutions within everyone's grasp. Contact Carter Holt Harvey for your free copy. Then simply update automatically using the "Check for updates" feature.



Floor layout and take-off service

Distributors of hyJOIST now provide floor layouts using layITout® - a fully integrated design and layout software developed by Timberbuilt for Carter Holt Harvey to support a more efficient floor system design with hyJOIST. Simply contact your distributor and enquire about the availability of this service.

Timberbuilt

This publication was prepared by Timberbuilt for Carter Holt Harvey.
Timberbuilt may be contacted using the Technical Enquiries number given below.

Available From:

22 Prospect Street
PO Box 425
Box Hill Victoria 3128
Australia

General Enquiries
Freecall 1800 284 792
Facsimile (08) 8739 7313

Technical Enquiries
Freecall 1800 808 131
Telephone(03) 9793 9997
Facsimile (03) 9793 9727

www.chhfuturebuild.com

 **CarterHoltHarvey**